

CSC 180, Exam II

Exam II Notes

- You may bring one page of notes (front and back) to the exam. This page may be handwritten or typed.
- Computer access will not be permitted during the exam.
- Cell phones must be put away at all times – but you may use calculators
- Don't hesitate to contact me if you have any questions!

Exam II Concepts

- Machine representation of data
 - Conversion from binary to decimal and decimal to binary
 - Conversion from hexadecimal to **binary decimal**
 - Finding a two's complement from a binary value
- Boolean Logic and Gates
 - Interpreting a transistor diagram: whether the switch is “open” or “closed”, and whether the transistor is “on” or “off”
 - Construction of truth tables
 - Boolean operations: AND, OR, NOT, NOR, NAND, and XOR
 - Circuit construction using logic gates
 - Sub-circuits, half adder, and full adder
- Computer architecture terminology
 - Transistor
 - Gate
 - Combinational vs Sequential Circuit
 - Central processing unit (CPU)
 - Random access memory (RAM)
 - Memory address register (MAR) and memory data register (MDR)
 - Fetch vs Store
 - Decoder and multiplexer
 - Machine language
 - Instruction set
 - Program counter
 - Instruction register
 - Fetch/Decode/Execute phases
 - SR-Latch
 - Flip-Flop
 - Clock pulses

Additional Practice Problems

1. See the Jupyter Notebook for practice converting between decimal, binary, and hex, and for finding the two's complement of a number
2. Use Boolean logic to write a condition corresponding to the following:
 - a. A number (*num*) is between 1 and 100
 - b. A person is not a sophomore
3. Complete the following Truth Table:

a	b	NOT a AND b
0	0	
0	1	
1	0	
1	1	

4. Specify the Boolean expression corresponding to the following Truth Table:

a	b	??
0	0	0
0	1	1
1	0	0
1	1	1

5. Specify the Boolean expression corresponding to the following Truth Table:

a	b	c	???
0	0	0	0
0	0	1	0
0	1	0	0
0	1	1	0
1	0	0	0
1	0	1	1
1	1	0	1
1	1	1	1

6. The circuit for a single bit magnitude comparator is shown below. For (1) through (4), specify the output of the circuit at that point, based on the circuit diagram below.

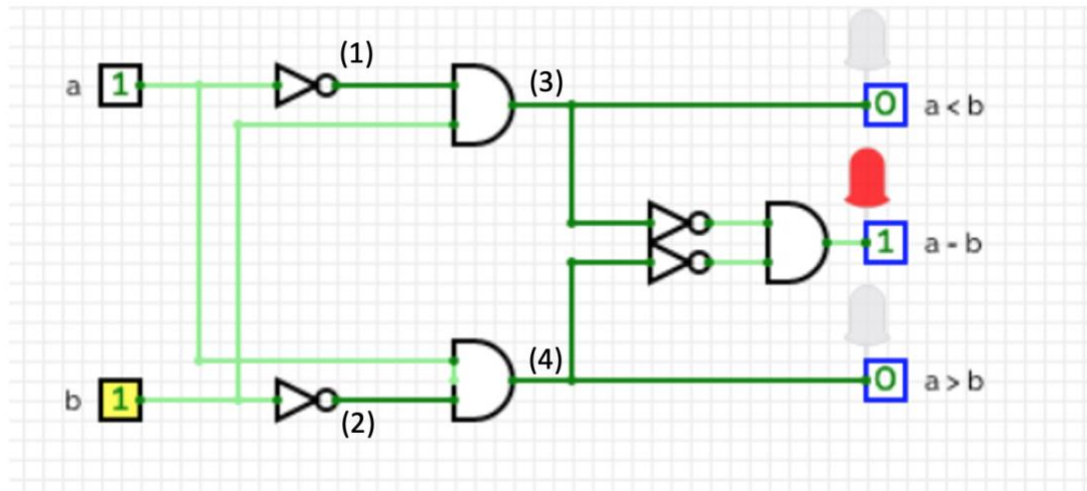

7. Construct a circuit diagram that implements the following Boolean expression: $a \text{ AND } b \text{ OR } (\text{NOT } a \text{ AND } c)$
8. Consider the machine language instruction example below, and fill in the blanks to describe (partially) how this instruction is executed.

ADD	X	Y
00001001	0000000000001001	000000000001100
op code for ADD	address of X	address of Y

For this instruction to execute, the address of X is copied to the _____ and the value of X is copied to the _____. The value of X is next copied to a register connected to the ALU. The ALU executes several arithmetic and logical operations, and a _____ is used to select the output of the ADD operation.